



METAL FORM MANUFACTURING CO., INC
 5960 WEST WASHINGTON STREET
 PHOENIX, ARIZONA 85043
 TELEPHONE: 602-233-1211 FAX: 602-233-2033
 WEBSITE ADDRESS: WWW.MFMCA.COM

Model MFES-24 Fabricated Equipment Screen 4" Deep Plain Blade

Specifications

Frame: 1 1/2" x 1 1/2" x 1/8" galvanized steel angle frame attached at approximately 48" centers.
Blades: 18ga. galvanized steel.
Finish: Standard mill.
Minimum size: 12"w x 12"h.
Maximum size: Unlimited.

Options

- Architectural mullions.
- Finishes.
- Other options available, consult factory.

Notes

1. Width x height are actual dimensions.
 Unless specified otherwise, units will be constructed exact size.
2. Metal Form reserves the right to improve design or change specifications at any time.

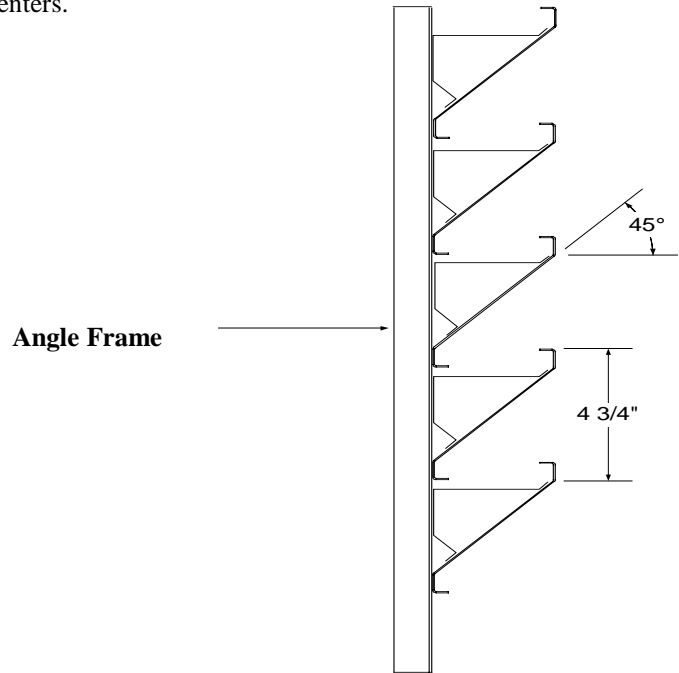

Section View

Tag	Qty.	Width	Height	No. of Panels (W x H)	Options	Finishes/Specify	Remarks

Project: _____
Architect: _____
Engineer: _____
Contractor: _____