

## **TECHNICAL DATA**

### **MicroProcessor Regulated Water Supply System**

MPR-01AW

#### ***Features***

- **Requires Only a Single 24VAC Power Source**
- **All Solid State (no moving parts)**
- **State-of-the-art Digital Electronics**
- **Manufactured using SMT (Surface Mount Technology) Components**
- **Optional Automatic Freeze Protection Plug-in Board**
- **Programmable ON Time Compensate for Varying Flow Rates**
- **Programmable OFF Schedule to Compensate for Climatic Conditions**
- **Optional Remote Thermometer and Remote Calibration Control**
- **Selectable Minimum Operating Temperature**
- **Completely Automatic Operation**
- **User Friendly Design**

#### ***Description***

The Energy Saver Microprocessor Regulator Water Supply System (MPR-01AW) is a powerful CMOS micro computer requiring only a single 24VAC power source. It is designed to measure the ambient air temperature and use this information to open and close a 24VAC electrically controlled valve using a predetermined time schedule. This valve then delivers water to the evaporative system's media in the most efficient manner.

A crystal oscillator provides a high frequency clock for the micro processor as well as a high resolution time base for accurately controlling the on and off times of the valve drive electronics. An on-board or optional remote digital thermostat provides 0.5° C (0.9° F) resolution for accurate temperature measurements. The system will auto-detect the presence of an optional remote thermometer and if present, will use it for its temperature measurements.

The system will also auto-detect the presence of an optional plug-in board which adds the capability to automatically protect the system supply plumbing from damage caused by unexpected freezing temperatures.

The Energy Saver Microprocessor Regulator Water Supply System (MPR-01AW) provides a highly reliable digital solution to improving the efficiency of the evaporative system and increasing the life span of the evaporative media.

## Block Diagram

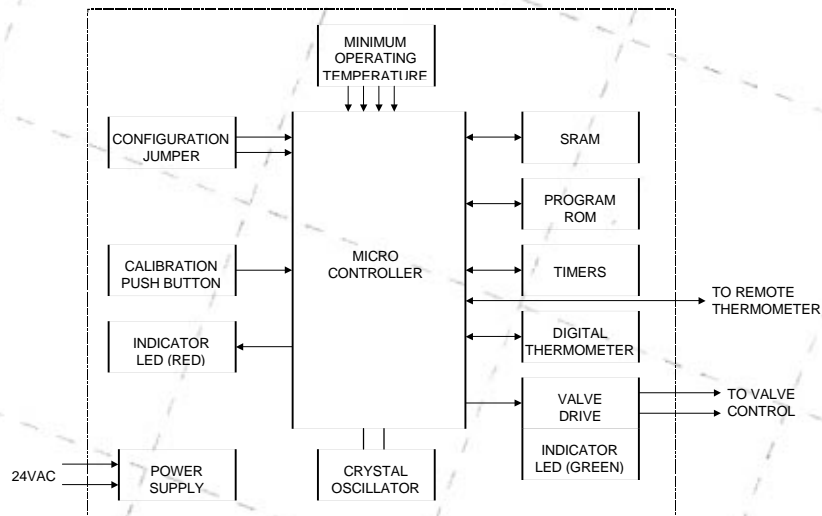

## Specifications

POWER SUPPLY INPUT	24VAC - 60 Hz @ 40VA
VALVE CONTROL OUTPUT	24VAC - 60 Hz @ 10VA

## AUTO-FREEZE OPTION

SUPPLY VALVE CONTROL OUTPUT	24VAC - 60 Hz @ 10VA
DRAIN VALVE CONTROL OUTPUT	24VAC - 60 Hz @ 10VA

## USER CONTROLS AND INDICATORS

- Configuration jumper for default time schedule selection.
- Four-bit DIP switch for setting the minimum operating temperature.
- Momentary push button for calibration control.\*
- Red LED (Light Emitting Diode) indicates the status of the system.\*
- Green LED glows when valve is open.

\* Also include for calibration control at the location of the remote thermostat.

### ***Functional Description***

The Energy Saver Microprocessor Regulator Water Supply System (MPR-01AW) provides a simple yet powerful architecture to meet the system application requirements.

The power supply uses the 24VAC input signal to create 5VDC to power the micro controller and the other low voltage digital components.

The program ROM (Read-Only Memory) is programmed at the factory to provide the system operation that is detailed in this document.

The system timers use the divided-down crystal frequency and are programmed to provide interrupts to the micro controller at a specific elapsed time or at regular time intervals.

The MPR-01AW communicates with the digital thermostat at regular time intervals and uses the current and average temperatures to control the timing of the valve control.

If a remote thermostat is detected at power-on, it will be used for temperature measurements rather than the on-board thermometer. It also interacts with the user for testing and calibration and continually displays status information.

At the heart of the MPR-01AW software is a real-time multi-tasking operating system. The operating system is tightly coupled with the application program to provide efficient use of the available memory space and to provide complete turn-key operation with no user intervention required. However, the user can easily interrupt the normal operation of the system to perform testing and calibration functions.

The application program is a state machine. That is, the program runs in a continuous loop and the behavior while inside the loop changes according to the current state of the system. This type of program provides very robust code because every operating state of the system can be clearly defined and the executive code processes events according to the rules of that state. Certain events can cause state transitions. These events can be timed events, button pressed events, or temperature related events.

### Configuration

Jumper header J2 selects the appropriate timing table for one of three different unit sizes. See the Timing Tables section for the actual time schedules for each configuration.

Installing the suitcase jumper across pins 1 and 2 selects the small (12" to 36") size. Installing the suitcase jumper across pins 2 and 3 selects the medium (37" to 48") size. Installing the suitcase jumper across pins 3 and 4 selects the large (49" to 72") size. The jumper position may be moved at any time but should only be changed in a power-off state. The position of the jumper is read by the system software only once during system initialization which occurs immediately after power is applied. Moving the jumper while power is on will have no effect on system operation.

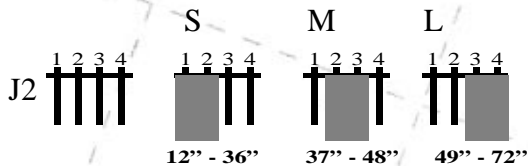

### Switch Settings

The minimum operating temperature is adjustable over a 15° C (27° F) range by setting the four switch positions according to the table below.

Minimum Operating Temperature		SWITCH POSITIONS (S2)			
°C	°F	1	2	3	4
26	78.8	OFF	OFF	OFF	OFF
25	77.0	ON	OFF	OFF	OFF
24	75.2	OFF	ON	OFF	OFF
23	73.4	ON	ON	OFF	OFF
22	71.6	OFF	OFF	ON	OFF
21	69.8	ON	OFF	ON	OFF
20	68.0	OFF	ON	ON	OFF
19	66.2	ON	ON	ON	OFF
18	64.4	OFF	OFF	OFF	ON
17	62.6	ON	OFF	OFF	ON
16	60.8	OFF	ON	OFF	ON
15	59.0	ON	ON	OFF	ON
14	57.2	OFF	OFF	ON	ON
13	55.4	ON	OFF	ON	ON
12	53.6	OFF	ON	ON	ON
11	51.8	ON	ON	ON	ON

### Connections

J1 is a terminal block connector for supplying power input to the board and provides outputs for connecting up to three electronically controlled valves.

The main board controls only the microprocessor regulated valve and the electronic control for this valve connects to pins 3 and 4 of the terminal block.

The supply and drain valve controls are active only if the Automatic Freeze Protection Optional board is installed and the drain time on that board is set to a non-zero value.

Connect the 24VAC power source for the board to pins 1 and 2 of the terminal block.

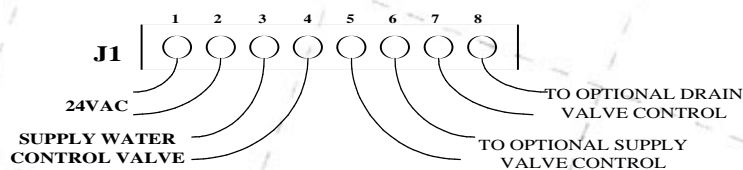

### Calibration

Calibration mode provides a means of changing the valve open time from its default value to adjust for varying flow rates and the valved closed schedule to compensate for climatic conditions.

To enter calibration mode, press and hold the calibration pushbutton for two seconds or until the indicator light flashes at a rapid rate, then release the pushbutton. If the valve is currently open it will then close and the unit will wait indefinitely for another button press. Press and release the calibration button, the valve opens and the blink rate slows. When sufficient water has flowed through the system, press and release the button again and the valve will close (starting the off calibration cycle).

The time that the water has been flowing through the system during this procedure will be saved as the calibrated time for all future valve open cycles. When the media starts to dry, press and release the calibration button once again and this time will be the calibrated time for all future valve closed cycles at this temperature.

The calibrated times are stored in non-volatile memory so that they will be remembered even if power is removed from the unit.

The calibrated times are stored as offsets and therefore have a maximum range of  $\pm 100\%$  of the default value. These offsets are cleared upon entering calibration mode. So, to restore the default times, simply enter calibration mode and then turn off the unit.

When power is restored, the system will use the default times for the selected configuration.

To calibrate the on time but still use the default off schedule, complete the on time portion of the calibration procedure. Then, at any time during the off calibration cycle, turn off the unit. When power is restored, the system will use the calibrated on time with the default off schedule.

### ***Operation***

When power is applied to the unit, system operation is completely automatic.

The system monitors the ambient air temperature and controls the on and off timing of the water supply valve according to one of three schedules selected by the configuration jumper.

An on cycle will start only if the ambient air temperature is equal to or greater than the minimum operating air temperature selected by the switch settings and will run for a fixed amount of time. The time will be either the calibrated time or the default time if the unit has never been calibrated or the calibration offset has been cleared. Off cycle times vary inversely with ambient air temperature. During the course of an off cycle, the air temperature is sampled at regular intervals so that each off cycle time is based on the average temperature sampled during that period.

Once power is applied, it is easy to determine the status of the system by observing the indicator lights. The green light simply follows the state of the valve and is on whenever the valve is open. The red light blinks at different rates and duty cycles to indicate the current state of the system.

### ***System Status Indicator***

<b>Red Indicator Light</b>	<b>System Status</b>
On steady for three seconds*	Power-on initialization
Normally off and blinks on momentarily at one second intervals	Valve open state
Normally on and winks off momentarily at one second intervals	Valve closed state
Normally off and blinks on momentarily four times per second	Pre-calibration state
Equal on and off times 1/4 of a second	Calibration states
Normally off and blinks on momentarily at two second intervals	Idle state - temperature is below the minimum operating temperature
Normally off and blinks on momentarily two times per second	Auto-freeze algorithm in progress - temperature has dropped below freeze setting
Normally off and blinks on momentarily at five second intervals	Frozen state - system is drained and temperature does not exceed freeze setting
On steady for five seconds	Thaw state - system is drained and temperature exceeds freeze setting

\* If the light winks off momentarily during this three second interval, then the system has detected a remote thermometer and it will use it for all temperature measurements rather than the on-board thermometer.

### Timing Tables

Temperature	DEFAULT ON TIMES (VALVE OPEN)		
	S	M	L
< Minimum *	0	0	0
>= Minimum *	32.70	47.00	56.50

\* The minimum operating temperature is selectable by setting the switch positions according to the table in the Switch Settings section.

Temperature		DEFAULT OFF SCHEDULE (VALVE CLOSED)		
°C	°F	S	M	L
10	<b>50.0</b>	132.61	122.35	97.61
12	<b>53.6</b>	131.49	120.83	96.49
14	<b>57.2</b>	130.37	119.31	95.37
16	<b>60.8</b>	129.25	117.79	94.25
18	<b>64.4</b>	128.13	116.27	93.13
20	<b>68.0</b>	127.01	114.75	92.01
22	<b>71.6</b>	125.89	113.23	90.89
24	<b>75.2</b>	124.77	111.71	89.77
26	<b>78.8</b>	123.65	110.19	88.65
28	<b>82.4</b>	122.53	108.67	87.53
30	<b>86.0</b>	121.41	107.15	86.41
32	<b>89.6</b>	120.29	105.63	85.29
34	<b>93.2</b>	119.17	104.11	84.17
36	<b>96.8</b>	118.05	102.59	83.05
38	<b>100.4</b>	116.93	101.07	81.93
40	<b>104.0</b>	115.81	99.55	80.81
42	<b>107.6</b>	114.69	98.03	79.69
44	<b>111.2</b>	113.57	96.51	78.57
46	<b>114.8</b>	112.45	94.99	77.45
48	<b>118.4</b>	111.33	93.47	76.33
50	<b>122.0</b>	110.21	91.95	75.21

All times are in seconds.