

Sound Attenuator

NO. 801-97



Commercial Acoustics

5960 W. WASHINGTON ST.
PHOENIX, ARIZONA 85043-3523
(602) 233-2322 FAX 233-2033

A DIVISION OF METAL FORM MANUFACTURING

ENGINEERING DATA

MODEL NF-SDS20

CIRCULAR

NOMENCLATURE EXAMPLE:

DIAMETER	LENGTH	MODEL
24 Ø	48	NF-SDS20-HP

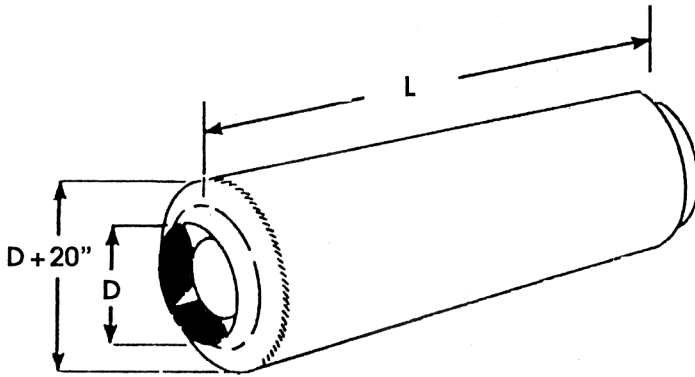

Commercial Acoustics products are engineered to deliver superior sound attenuation. Their effectiveness is driven by their quality construction and material components. Each Commercial Acoustic sound attenuator utilizes an innovative engineered metallic material called Feltmetal. The unique Interlocked structure of Feltmetal's metal fibers are bonded at all the points where the fibers contact with each other. The structural continuity of the fibrous network provides exceptional mechanical properties at low and intermediate densities compared to other sintered, non-fibrous material structures.

MODEL NO.	OCTAVE BANDS	(1)	(2)	(3)	(4)	(5)	(6)	(7)	(8)
	CENTER FREQUENCY (Hz)	63	125	250	500	1000	2000	4000	8000
	FACE VELOCITY FPM	DYNAMIC INSERTION LOSS IN DECIBELS							
NF-SDS20-HP	-2000	9	16	28	28	20	19	16	17
	-1000	8	16	27	28	20	19	17	17
	0	9	15	28	28	20	21	17	18
	+1000	7	13	26	27	19	20	18	18
	+2000	7	13	26	27	19	21	18	19
NF-SDS20-LP	-2000	8	13	26	25	14	14	12	13
	-1000	7	14	15	15	14	15	14	15
	0	8	15	31	25	14	15	12	13
	+1000	7	11	25	24	13	15	12	13
	+2000	7	11	24	24	13	15	12	13

THIS TABLE CONTAINS BOTH FORWARD (+) AND BACKWARD (-) FLOW ACOUSTIC AND AERODYNAMIC RATINGS BASED ON TEST RESULTS MEASURED IN ACCORDANCE WITH ASTM E477. COPIES OF THESE TEST REPORTS CAN BE FURNISHED UPON REQUEST.

Sound Attenuator

CIRCULAR MODEL NF-SDS20

ENGINEERING DATA

STATIC PRESSURE LOSS IN H2O

MODEL	NF-SDS20-HP	0.17	0.26	0.41	0.58	0.79	1.03	1.30	1.59	1.92
	NF-SDS20-LP	0.12	0.19	0.29	0.42	0.56	0.74	0.93	1.14	1.38
	VELOCITY	1780	2350	2920	3490	4060	4635	5210	5775	6345
SIZE D x L	FACE AREA	AIR FLOW IN CFM								
12 x 36	0.79	1406	1857	2307	2757	3207	3662	4116	4562	5013
14 x 36	1.07	1905	2515	3124	3734	4344	4959	5575	6179	6789
16 x 36	1.40	2492	3290	4088	4886	5684	6489	7294	8085	8883
18 x 36	1.77	3151	4160	5168	6177	7186	8204	9222	10222	11231
20 x 40	2.18	3880	5123	6366	7608	8851	10104	11358	12590	13832
22 x 44	2.64	4699	6204	7709	9214	10718	12236	13754	15246	16751
24 x 48	3.14	5589	7379	9169	10959	12748	14554	16359	18134	19923
26 x 52	3.69	6568	8672	10775	12878	14981	17103	19225	21310	23413
28 x 56	4.28	7618	10058	12498	14937	17377	19838	22299	24717	27157
30 x 60	4.91	8740	11539	14337	17136	19935	22758	25581	28355	31154
32 x 64	5.58	9932	13113	16294	19474	22655	25863	29072	32225	35405
36 x 72	7.07	12585	16615	20644	24674	28704	32769	36835	40829	44859
40 x 80	8.73	15539	20516	25492	30468	35444	40464	45483	50416	55392
44 x 88	10.56	18797	24816	30835	36854	42874	48946	55018	60984	67003
48 x 96	12.57	22375	29540	36704	43869	51034	58262	65490	75292	79757
52 x 104	14.75	26255	34633	43070	51478	59885	68366	76848	85181	93589
56 x 112	17.10	30438	40185	49932	59679	69426	79259	89091	98091	108500
60 x 120	19.63	34941	46131	57320	68509	79698	90985	102272	113363	124552

Air flow ratings shown include static regain. Therefore if silencers are installed immediately before or after elbows, transitions, at the intake or discharge of the system, or without duct, allowance to compensate for such conditions must be included when calculating the operating pressure loss thru the silencer. Failure to make allowance for these conditions can add several velocity heads to the pressure loss of the system. All acoustic and aerodynamic performance obtained on 24" x 24" cross section production units.

SELF-GENERATED SOUND POWER RATINGS (PWL) dB re 10⁻¹² WATTS

OCTAVE BAND		1	2	3	4	5	6	7	8
HZ		63	125	250	500	1000	2000	4000	8000
MODEL	FACE VELOCITY								
SDS20-HP	-2000	54	48	40	40	43	41	33	24
	-1000	54	48	40	42	42	43	35	22
	+1000	58	50	38	45	42	45	37	22
	+2000	51	44	39	39	41	36	29	20
SDS20-LP	-2000	52	46	40	49	36	35	32	21
	-1000	52	45	38	51	36	36	33	21
	+1000	50	46	37	47	45	46	41	24
	+2000	50	45	37	38	40	38	29	20

SELF-GENERATED SOUND RATINGS/FACE AREA ADJUSTMENT FACTORS

FACE AREA	.40	.53	.66	.79	1.0	1.26	1.5	2.0	2.5	3.0
PWL ADJUSTMENT FACTOR, dB	-3	-2	-1	0	+1	+2	+3	+4	+5	+6