

Sound Attenuator

No. 802-06



Commercial Acoustics
5960 W. WASHINGTON STREET
PHOENIX, ARIZONA 85043-3523
(602) 233-2322 FAX 233-2033

A DIVISION OF METAL FORM MANUFACTURING

CERTIFIED ENGINEERING DATA SHEET

MODEL 18CNF-LP

CIRCULAR NO-FILL LOW PRESSURE LOSS

NOMENCLATURE EXAMPLE:

INLET	LENGTH	MODEL
18	36	18CNF-LP

Commercial Acoustics sound attenuators are engineered to achieve a maximum insertion loss and a minimum pressure drop. Commercial Acoustics sound attenuators feature airfoil design for efficient aerodynamic performance, as well as superior acoustical materials and total galvanized steel construction guaranteeing excellent reliability and performance. DIL is achieved by use of tuned resonators. No acoustical fill is used.

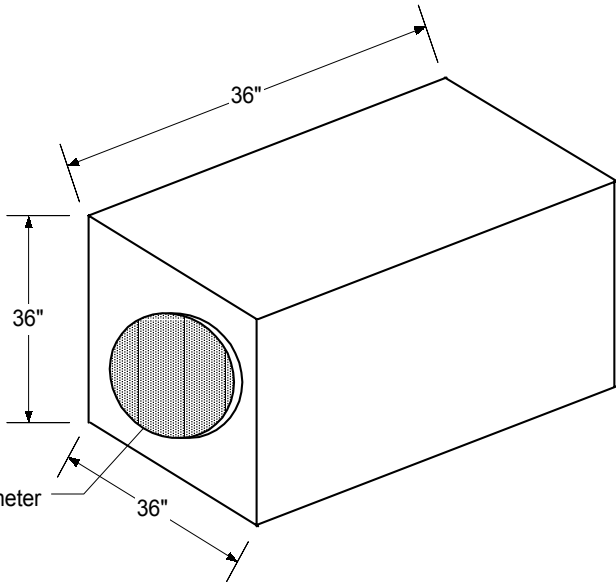

TABLE I

OCTAVE BAND	(1)	(2)	(3)	(4)	(5)	(6)	(7)	(8)
CENTER FREQUENCY, Hz	63	125	250	500	1000	2000	4000	8000
SILENCER FACE VELOCITY, fpm	DYNAMIC INSERTION LOSS IN DECIBELS							
-2000	12	7	19	5	6	5	4	4
-1000	12	6	16	4	5	5	4	4
0	11	6	16	4	5	5	4	3
+1000	12	6	16	4	5	5	4	3
+2000	12	7	18	5	5	5	4	3

TABLE II

OCTAVE BAND	(1)	(2)	(3)	(4)	(5)	(6)	(7)	(8)
CENTER FREQUENCY, Hz	63	125	250	500	1000	2000	4000	8000
SILENCER FACE VELOCITY, fpm	SELF-NOISE SOUND POWER LEVELS, dB re: 10 ⁻¹² WATTS							
-2000	64	62	55	50	49	47	42	33
-1000	63*	47*	36	32	26	22*	27*	31*
+1000	62*	45*	33*	29	22*	21*	28*	32*
+2000	67	54	46	44	46	43	34	33*

* Denotes data that has reached ambient levels in the test room or is determined by instrument limitations. Actual levels are less than or equal to the level shown.

Static Pressure Loss, Model **18CNF-LP** = 0.010 in.wc. @ 1000 fpm face velocity

Actual fpm = Actual CFM ÷ 1.767 square feet.

For intermediate velocities: $\left(\frac{\text{Actual Velocity}}{1000}\right)^2 \times 0.010 \text{ in. wc.} = \text{Actual Pressure Loss}$

THESE TABLES CONTAIN BOTH FORWARD(+) AND REVERSE(-) FLOW ACOUSTIC AND AERODYNAMIC RATINGS WHICH ARE THE TEST RESULTS FROM AN INDEPENDENT NVLAP CERTIFIED LABORATORY MEASURED IN ACCORDANCE WITH ASTM E477-99. COPIES OF THESE TEST REPORTS CAN BE FURNISHED UPON REQUEST.