

# Sound Attenuator

NO. 765-89

SUPERSEDES NO. 764-89



Commercial Acoustics

5960 W. WASHINGTON ST.  
PHOENIX, ARIZONA 85043-3523  
(602) 233-2322 FAX 233-2033

A DIVISION OF METAL FORM MANUFACTURING

## ENGINEERING DATA SHEET

# MODEL SDS

## CIRCULAR

### NOMENCLATURE EXAMPLE:

DIAMETER	LENGTH	MODEL
24 Ø	48	SDS-HP

Commercial Acoustics sound attenuators are engineered to achieve a maximum insertion loss with a minimum pressure drop. Commercial Acoustics sound attenuators feature airfoil design for efficient aerodynamic performance, as well as superior acoustical materials and totally galvanized steel construction, guaranteeing excellent reliability and performance.

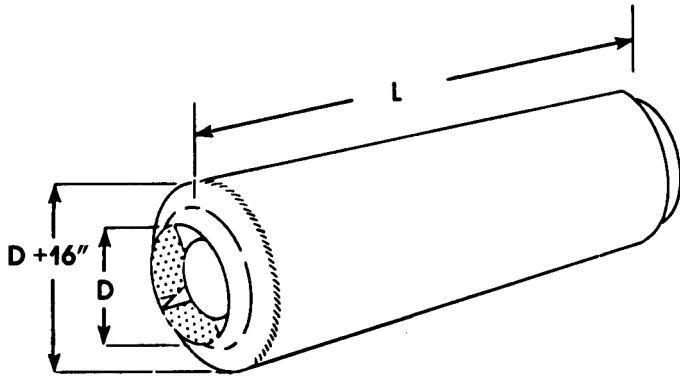

MODEL NO.	OCTAVE BANDS	(1)	(2)	(3)	(4)	(5)	(6)	(7)	(8)
	CENTER FREQUENCY (Hz)	63	125	250	500	1000	2000	4000	8000
	FACE VELOCITY FPM	DYNAMIC INSERTION LOSS IN DECIBELS							
SDS-HP	-4000	10	17	30	40	41	35	22	13
	-2000	9	15	28	39	38	36	23	16
	0	8	11	19	33	35	37	24	18
	+2000	7	12	25	32	36	35	25	19
	+4000	6	11	21	31	33	37	24	21
SDS-MP	-4000	7	15	25	35	38	29	18	12
	-2000	6	14	24	34	35	30	19	15
	0	5	10	18	30	33	30	20	18
	+2000	5	11	23	28	31	29	21	18
	+4000	4	10	18	27	30	28	21	17
SDS-LP	-4000	6	12	22	33	33	22	18	12
	-2000	5	11	20	30	32	23	19	12
	0	4	9	16	28	31	24	20	16
	+2000	4	10	18	26	30	23	20	16
	+4000	3	9	17	24	29	25	21	15

THIS TABLE CONTAINS BOTH FORWARD (+) AND BACKWARD (-) FLOW ACOUSTIC AND AERODYNAMIC RATINGS BASED ON TEST RESULTS MEASURED IN ACCORDANCE WITH ASTM E477. COPIES OF THESE TEST REPORTS CAN BE FURNISHED UPON REQUEST.

# Sound Attenuator

CIRCULAR MODEL SDS

## ENGINEERING DATA

### STATIC PRESSURE LOSS IN INCHES H2O

MODEL	SDS-HP	0.15	0.26	0.40	0.58	0.78	1.01	1.27	1.54	1.86
	SDS-MP	0.07	0.12	0.18	0.27	0.36	0.46	0.57	0.70	0.85
	SDS-LP	0.06	0.10	0.16	0.23	0.31	0.40	0.50	0.61	0.74
	VELOCITY	1780	2350	2920	3490	4060	4635	5210	5775	6345
SIZE D x L	FACE AREA	AIR FLOW IN CFM								
12 x 36	0.79	1406	1857	2307	2757	3207	3662	4116	4562	5013
14 x 36	1.07	1905	2515	3124	3734	4344	4959	5575	6179	6789
16 x 36	1.40	2492	3290	4088	4886	5684	6489	7294	8085	8883
18 x 36	1.77	3151	4160	5168	6177	7186	8204	9222	10222	11231
20 x 40	2.18	3880	5123	6366	7608	8851	10104	11358	12590	13832
22 x 44	2.64	4699	6204	7709	9214	10718	12236	13754	15246	16751
24 x 48	3.14	5589	7379	9169	10959	12748	14554	16359	18134	19923
26 x 52	3.69	6568	8672	10775	12878	14981	17103	19225	21310	23413
28 x 56	4.28	7618	10058	12498	14937	17377	19838	22299	24717	27157
30 x 60	4.91	8740	11539	14337	17136	19935	22758	25581	28355	31154
32 x 64	5.58	9932	13113	16294	19474	22655	25863	29072	32225	35405
36 x 72	7.07	12585	16615	20644	24674	28704	32769	36835	40829	44859
40 x 80	8.73	15539	20516	25492	30468	35444	40464	45483	50416	55392
44 x 88	10.56	18797	24816	30835	36854	42874	48946	55018	60984	67003
48 x 96	12.57	22375	29540	36704	43869	51034	58262	65490	72592	79757
52 x 104	14.75	26255	34663	43070	51478	59885	68366	76848	85181	93589
56 x 112	17.10	30438	40185	49932	59679	69426	79259	89091	98753	108500
60 x 120	19.63	34941	46131	57320	68509	79698	90985	102272	113363	124552

Air flow ratings shown include static regain. Therefore if silencers are installed immediately before or after elbows, transitions, at the intake or discharge of the system, or without duct, allowance to compensate for such conditions must be included when calculating the operating pressure loss thru the silencer. Failure to make allowance for these conditions can add several velocity heads to the pressure loss of the system.

### SELF-GENERATED SOUND POWER RATINGS (PWL) dB re 10<sup>-12</sup> WATTS

MODEL	OCTAVE BANDS	(1)	(2)	(3)	(4)	(5)	(6)	(7)	(8)
	CENTER FREQUENCY (Hz)	63	125	250	500	1000	2000	4000	8000
	FACE VELOCITY FPM								
SDS-HP	-4000	62	63	64	63	62	64	64	62
	-2000	51	49	50	48	47	48	46	40
	+2000	57	55	49	48	47	47	41	33
	+4000	72	68	66	67	61	63	63	60
SDS-MP	-4000	62	62	63	62	60	63	61	60
	-2000	49	48	50	47	45	47	41	35
	+2000	56	54	48	46	45	43	38	31
	+4000	70	67	64	66	60	61	59	56
SDS-LP	-4000	62	61	60	63	62	63	57	55
	-2000	48	46	47	46	44	45	38	30
	+2000	55	52	47	44	43	40	36	29
	+4000	69	66	62	63	60	60	56	51

### SELF-GENERATED SOUND RATINGS/FACE AREA ADJUSTMENT FACTORS

FACE AREA	.75	1.5	2	2.5	3.1	4.0	6.0	12	20
PWL ADJUSTMENT FACTOR, dB	-6	-3	-2	-1	0	+1	+3	+6	+8